

## Excessive Exhaust Smoke/Spark Plug Fouling – Mariner 40 Magnum/Mercury 40 Electric Start (4 Cyl.)

Outboards listed, may experience excessive exhaust smoke and spark plug fouling at slower engine speeds, due to an over rich oil pump delivery rate. Correction requires replacement of the oil pump cam plate. Replacement of complete oil pump is not necessary.

### MODELS:

United States ..... 0C265082 and below  
Belgium ..... 9604830 and below  
Canada ..... 0A756958 and below

### PARTS REQUIRED:

Qty 1      P/N 816862      Oil Pump Cam Plate

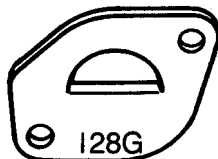

51018

Previous Oil Pump Cam Plate Marked "128G"

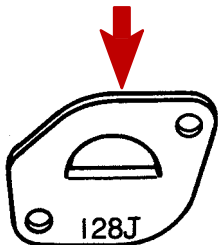

51018

New Oil Pump Cam Plate (P/N 816862)  
Marked "128J"

### QUICKSILVER:

Oil pump assembly with new  
cam plate "128J" ..... P/N 812690--1

### REPAIR PROCEDURE:

**IMPORTANT:** Note orientation of existing oil pump cam plate to the oil pump and install new cam plate in the same manner.

1. Remove (and retain) 2 phillips head screws securing oil pump cam plate to oil pump. (Figure 1)

### SERVICE TIP

Easy access to cam plate mounting screws, may be obtained by inserting a long shanked phillips screwdriver (such as P/N 91-24279) thru opening in battery cable grommet.

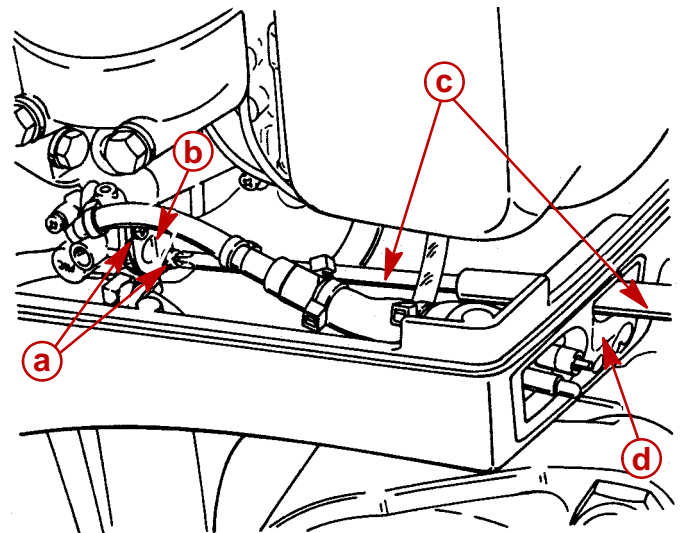

51019

Figure 1.

- a - Screw (2)
- b - Oil Pump Cam Plate
- c - Screwdriver (P/N 91-24279)
- d - Battery Cable Grommet

- Remove cam plate from oil pump, using a twisting motion to break the O-ring seal. Make sure O-ring and plunger located behind cam plate (Figure 2), remain in position.

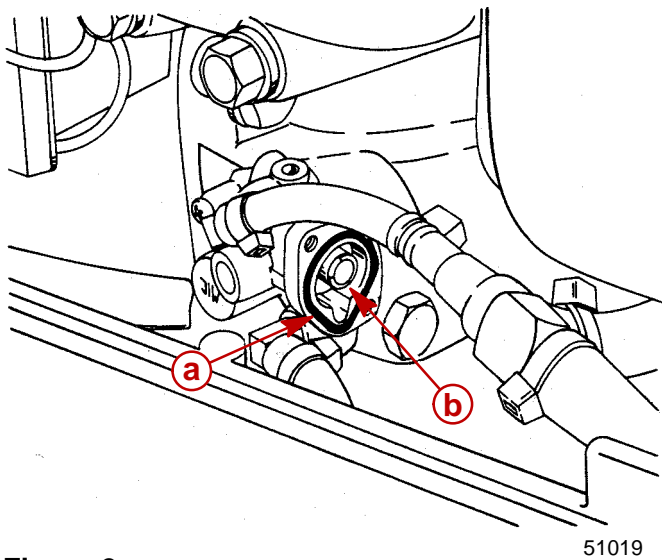

Figure 2.

- a - O-ring
- b - Plunger

- Secure new cam plate (marked "128J") onto oil pump, using retained screws. (Figure 3) Tighten screws to a torque of 5 lb. in. (0.6 Nm).

#### SERVICE TIP

Use a needle nose pliers to hold mounting screws, while starting screws with a screwdriver.

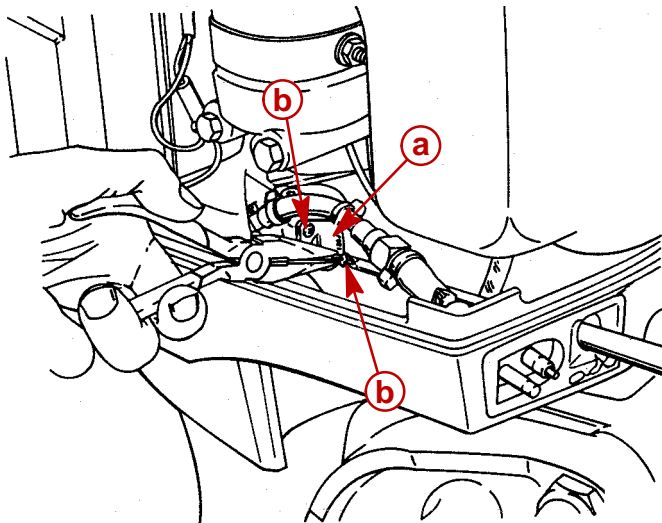

Figure 3.

- a - Oil Pump Cam Plate (Marked "128J")
- b - Screws

## BLEEDING AIR FROM OIL INJECTION SYSTEM

**IMPORTANT:** If air exists in either oil pump hose (inlet or outlet), the air **MUST BE** bled from the hose(s) or engine damage may occur.

### Bleeding Air from Oil Pump Inlet Hose

- With engine not running, place a shop towel below the oil pump. Loosen bleed screw three to four turns and allow oil to flow from bleed hole until no air bubbles are present in inlet hose. (Figure 4) Torque bleed screw to 25 lb. in. (2.8 Nm). This procedure also allows oil pump to fill with oil.

### Bleeding Air from Oil Pump Outlet Hose

- Purge air from outlet hose by running engine (on 50:1 gasoline/oil mixture in fuel tank) at idle speed until no air bubbles are present in outlet hose.

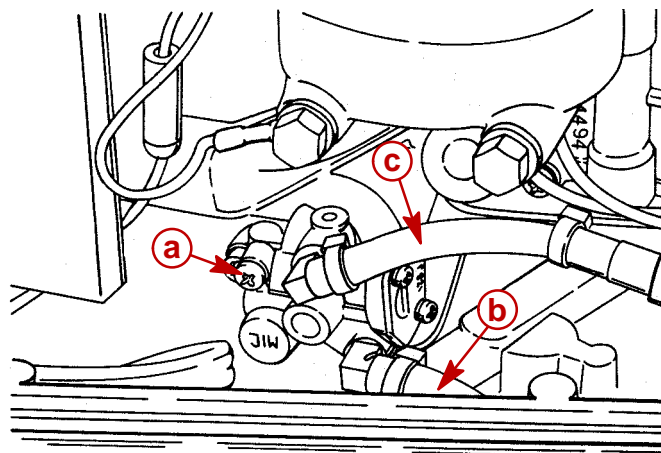

Figure 4

- a - Bleed Screw
- b - Inlet Hose
- c - Outlet Hose

#### WARRANTY:

Complete warranty claim listing;

Outboard serial number.

Qty. 1 P/N 816862 Oil Pump Cam Plate

One half (0.5) hour labor.